

1 THREE-PHASE SYSTEMS

- a) Explain two of the main advantages of using three-phase systems compared with single-phase systems for generation and transmission of electric energy.

Answer: The following are considered as the main advantages, but other answers may also give full score

- We can transmit more power per conductor (for a given insulation level), so three-phase is a more economic method for power transmission
- Power (and torque) in a three-phase system is constant, while it is pulsating in a single-phase machine. This will give less stress on components, and also a more smooth operation

Comment: It is not sufficient to say "we can transmit more power with three-phase", it must be specified that we can transmit more power for the same cost as a corresponding single-phase system

Consider the circuit below. You can assume without proof that the neutral points marked "n" are at the same potential (this is always true for balanced three-phase systems). The capacitors are marked with dashed lines since they will only be used in problems c, d and e.

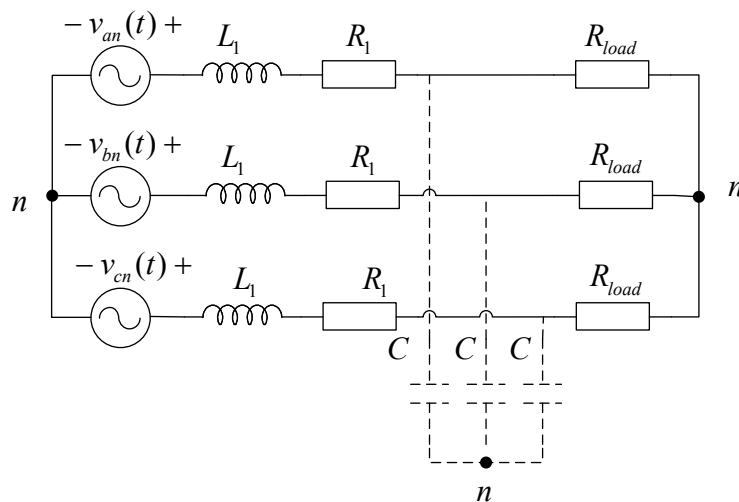

$$v_{an}(t) = 100 \sin(\omega t)$$

$$v_{bn}(t) = 100 \sin\left(\omega t - \frac{2\pi}{3}\right)$$

$$v_{cn}(t) = 100 \sin\left(\omega t + \frac{2\pi}{3}\right)$$

$$L_1 = 10 \text{ mH} \quad R_1 = 1 \Omega$$

$$R_{load} = 10 \Omega \quad f = 50 \text{ Hz}$$

- b) What is the magnitude of the line-to-line RMS voltage of the three-phase voltage source?

Answer: In assignment 8 we derived the relation between phase-to-neutral voltage and line-to-line voltage as:

$$\frac{|V_{LL}|}{|V_{ph}|} = \sqrt{3}, \text{ where both voltages are RMS. In our case the phase-to-neutral voltage has RMS-value of}$$

$$|V_{ph}| = \frac{100}{\sqrt{2}}, \text{ so the line-to-line RMS-voltage is:}$$

$$|V_{LL}| = |V_{ab}| = 100 \frac{\sqrt{3}}{\sqrt{2}} = 122.47 \text{ V}$$

Assume the capacitors marked with dashed lines are disconnected.

- c) Find the total active and reactive power delivered by the three-phase voltage source

Answer: We can make the “per phase” circuit diagram as follows:

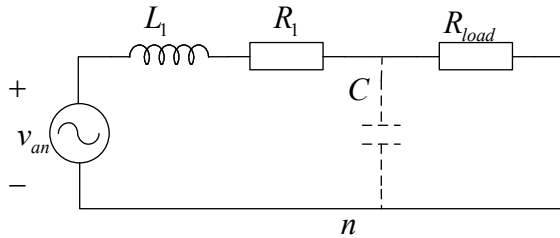

Without the capacitor, the total impedance seen from the voltage source is:

$$Z_{tot} = R_1 + R_{load} + j\omega L_1 = 11 + j3.141 = 11.44e^{j15.94^\circ}$$

The voltage RMS-phasor is $V_{an} = \frac{100}{\sqrt{2}}e^{j0} = 70.71e^{j0}$ (we define zero phase angle, but we could have chosen anything)

When finding the power from the three-phase source, we must multiply with 3 phases:

$$S = 3 \cdot \frac{|V_{an}|^2}{(Z_{tot})^*} = \frac{3 \cdot 5000}{11.44e^{-j15.94}} = 1311.9e^{j15.94}$$

$$P = 1311.9 \cos(15.94) = 1260.8 \text{ W}$$

$$Q = 1311.9 \sin(15.94) = 360.1 \text{ VAR}$$

Assume now that the capacitors are connected to the circuit

- d) Find the value of the capacitance C that makes the reactive power from the three-phase voltage source equal to zero.

Answer: We start by finding an expression from the total impedance with the capacitor included:

$$Z_{tot} = R_1 + j\omega L_1 + \frac{\frac{R_{load}}{j\omega C}}{R_{load} + \frac{1}{j\omega C}} = R_1 + j\omega L_1 + \frac{R_{load}}{1 + j\omega R_{load} C} = R_1 + j\omega L_1 + R_{load} \frac{1 - j\omega R_{load} C}{1 + (\omega R_{load} C)^2}$$

In the last equality we multiplied with the complex conjugate to remove the imaginary units from the denominator. The next step is to split this expression into real and imaginary parts:

$$Z_{tot} = R_1 + \frac{R_{load}}{1 + (\omega R_{load} C)^2} + j \left(\omega L_1 - \frac{\omega R_{load}^2 C}{1 + (\omega R_{load} C)^2} \right)$$

In order for the source to give zero reactive power, this impedance must be purely resistive (no imaginary part). This is equivalent to:

$$\omega L_1 = \frac{\omega R_{load}^2 C}{1 + (\omega R_{load} C)^2}$$

$$L_1 (\omega R_{load} C)^2 - R_{load}^2 C + L_1 = 0$$

$$9.869 \cdot 10^4 C^2 - 100C + 0.01 = 0$$

$$C = 901 \mu F \vee C = 112.5 \mu F$$

Comment: Some students find C by setting $\omega L_1 = \frac{1}{\omega C}$. This is not correct since L and C are not in parallel.

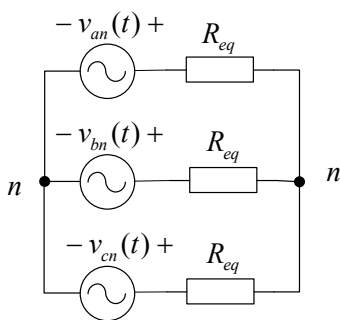

e) With your choice of C we can represent the three-phase load by an equivalent resistance R_{eq} as shown in the following figure.

What is the numerical value of R_{eq} ?

Answer: This is equivalent to the real part of Z_{tot} from d) since the imaginary part is now zero:

$$R_{eq} = R_1 + \frac{R_{load}}{1 + (\omega R_{load} C)^2}$$

Inserting the numeric values from d):

$$R_{eq} = 2.11 \Omega \vee R_{eq} = 9.89 \Omega$$

Comments to d) and e): It is sufficient to find only one of the two correct values.

2 SKI TOW POWERED BY INDUCTION MOTOR

In this task we will analyze the ski tow in the following figure. The ski tow consists of a rotating drum with radius $r=1.5\text{ m}$, where the ski tow wire is connected on the periphery as shown. The drum is rotating with rotational speed ω_{drum} . The drum is attached by a shaft to a mechanical gearbox, which again is connected to the motor shaft. The induction motor is connected to a 50 Hz voltage supply with constant voltage $V = 230\text{ V}$ (rms) (single-phase) and $\cos\varphi = 0.9$.

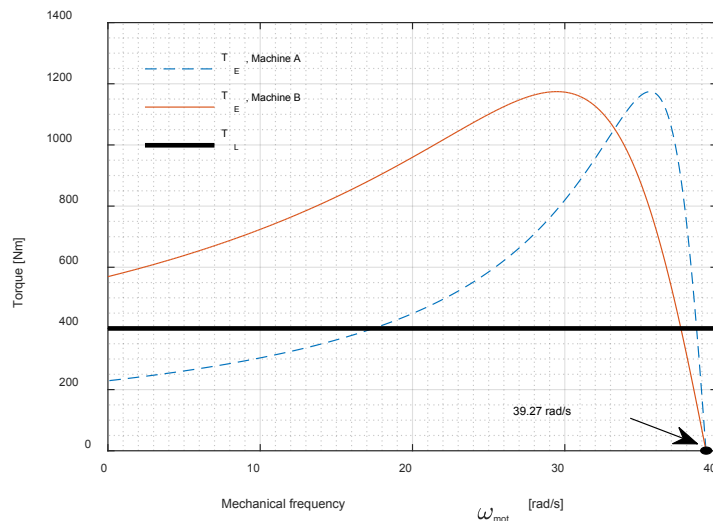
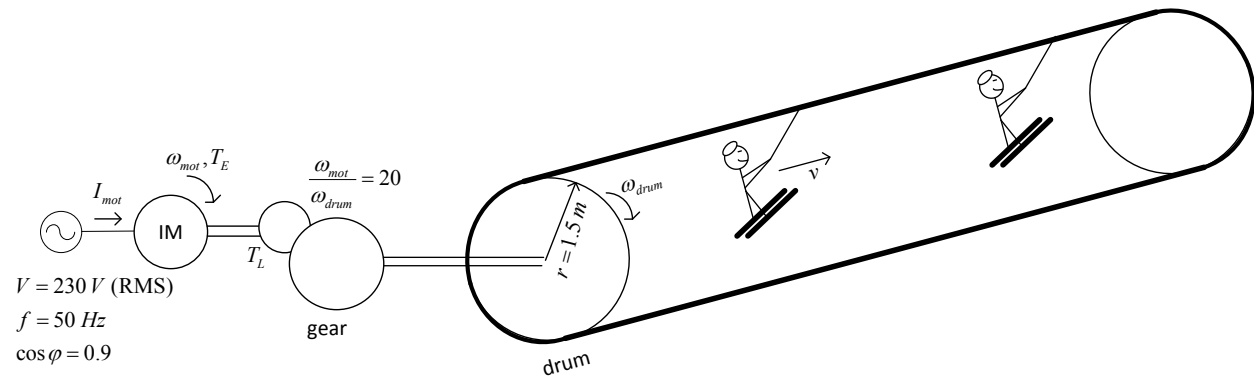

The load torque demand can be modelled as constant $T_L = 400\text{ Nm}$, referred to the motor side of the gear. The motor torque as a function of speed is given by the torque-speed curves. We have two available motors that we can use: A and B. Their torque-speed curves are shown to the left together with the load torque (thick line).

a) Mention one of the main challenges with start-up of induction machines. Which of the machines, A or B, would you recommend for the ski lift?

Answer: One main challenge is to get sufficient start-up torque. If the start-up torque is below the load torque at standstill, the motor will not rotate. We must therefore select a motor with start-up torque above the maximum expected load torque at standstill.

Based on this discussion, it is clear that machine A is useless for our ski tow, since its starting torque is 220 Nm, and the load torque is constant equal to 400 Nm. **Select machine B.**

There are other challenges with start-up of induction machines that also would give full score, for example the high starting current.

Comment: If machine B was chosen for incorrect reason, this could potentially give 0 points.

- b) With your choice of machine, find the following quantities:
- I. The number of poles of the induction machine
 - II. The power delivered to the ski tow
 - III. The current supplied from the motor at nominal conditions (neglect all losses)
 - IV. The speed v

Answer: The number of pole pairs can be found by dividing the electrical frequency (in rad/s) by the synchronous mechanical speed: $\frac{p}{2} = \frac{2\pi 50}{39.27} = 8 \Rightarrow p = 16$

Hence, there are **16 poles**. Those that forgot to multiply with 2 get a small point reduction. It is important to use 39.27 and not 37.5 or 38 here.

We can first find the mechanical speed of machine B. From the figure we read the intersection point between load torque and motor torque at $\omega_{mot} = 37.5$ rad/s. Students that used other values, e.g. 38 or 37 got full score, but students that used 39.25 for power calculation will get point reduction. We assume no losses throughout the system, so the power can be found directly as $P = \omega_{mot} T_L = 400 \cdot 37.5 = 15$ kW

The current supplied from the motor can be found as $P = VI \cos \varphi \Rightarrow I = \frac{P}{V \cos \varphi} = \frac{15000}{230 \cdot 0.9} = 72.46$ A (RMS)

The speed v : Find the speed of the low-speed side of the gear as $\omega_{drum} = \frac{37.5}{20} = 1.875$ rad/s. Then, we use the fact that the ski tow wire is attached to the drum with radius 1.5 m:
 $v = \omega_{drum} r = 1.875 \cdot 1.5 = 2.813$ m/s.

- c) If the load torque is suddenly reduced to $T_L = 0$ at $t = 0$, find the speed $v(t)$. Assume linearity in the torque-speed curve at the nominal operation range. Use $J_{tot} = 100$ kg · m² referred to the motor side of the gearbox.

Answer: We first utilize the linearity in the torque-speed curve to get the motor torque as a function of speed:

$$T_E(\omega) = k \cdot (\omega - \omega_s)$$

$$T_E(\omega_o) = T_L = k(\omega_o - \omega_s)$$

$$k = \frac{T_L}{(\omega_o - \omega_s)}$$

$$T_E(\omega) = T_L \cdot \frac{(\omega - \omega_s)}{(\omega_o - \omega_s)}$$

Where $T_L = 400$, $\omega_o = 37.5$, $\omega_s = 39.27$

NB: In this solution, ω refers to ω_{mot} , the mechanical speed of the motor.

We use numerical values in the following to get more simple expressions:

$$T_E(\omega) = 8874 - 226.0\omega$$

We can then insert this into the torque balance equation:

$$T_E(\omega) = J_{tot} \frac{d\omega}{dt}$$

$$J_{tot} \frac{d\omega}{dt} + 226.0\omega = -8874.6$$

$$\frac{d\omega}{dt} + 2.260\omega = -88.746$$

$$\omega(t) = Ae^{-2.26t} + B$$

We can find the two constants A and B by inserting:

- Initial condition $\omega(0) = 37.5$
- Insert the solution into the differential equation to obtain $2.26B = -88.74$ (could also insert $\omega(t \rightarrow \infty) = \omega_s$)

This gives

$$B = 39.27$$

$$A = 39.27 - 37.5 = 1.77$$

With the complete expression for ω :

$$\omega(t) = 39.27 - 1.77e^{-2.26t}$$

The speed v can be found by dividing by gear ratio and multiply by radius:

$$v = \frac{\omega_{mot}}{20} \cdot 1.5 = 2.945 - 0.1327e^{-2.26t} \text{ m/s}$$

Comment: Other numerical values could give full score since the answer depends on reading from the graph.

- d) The ski lift owner wants to operate the ski lift at controllable speed, i.e. be able to control the speed v independent of the load torque. Suggest a modification to the system in order to achieve this (make a sketch).

Answer: If we want controllable speed we should install a frequency converter between the grid and the motor. A suggested sketch is the following:

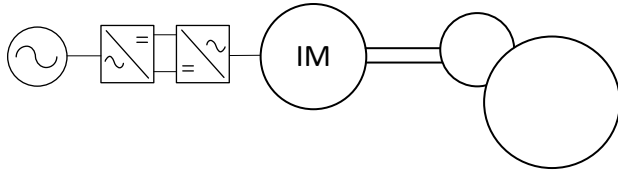

It is also correct to say rectifier+inverter.

Students that propose to use a gearbox to get variable speed only get a few points since it is very difficult to make an adjustable gearbox with controllability. We have only used gearboxes with fixed speed ratio in this course.

3 OP-AMP BASED HIGH PASS FILTER DESIGN

Consider the active filter in the figure with impedances Z_1 and Z_2 .

- a) We want to design a first-order high-pass filter. What components must be included in Z_1 and Z_2 in this case? Redraw the circuit with these components.

Answer: The correct schematic for the first-order high-pass active filter is the following:

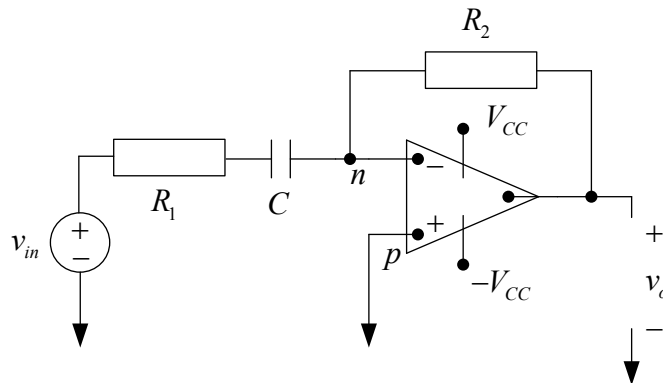

- b) The capacitor in the filter should be 250 nF . Find the parameter values of the other components if we want to have the cutoff frequency equal to $\omega_c = 4\text{ kHz}$ and a passband gain of 8.

Answer: We start by finding the transfer function (in frequency domain) of the active filter:

$$H(j\omega) = \frac{V_o(j\omega)}{V_{in}(j\omega)}$$

To find this transfer function we must use that the points “p” and “n” are at the same potential, and since “p” is at ground potential, so is “n”. The current from the input voltage source can then be found as:

$$I = \frac{V_{in}}{R_1 + \frac{1}{j\omega C}} = V_{in} \frac{j\omega C}{1 + j\omega C R_1}$$

The transfer function can now be found as:

$$V_{out} = -R_2 I = -V_{in} \frac{jR_2 \omega C}{1 + j\omega CR_1}$$

$$H(j\omega) = -\frac{jR_2 \omega C}{1 + j\omega CR_1} = -\frac{R_2}{R_1} \frac{j\omega R_1 C}{1 + j\omega R_1 C}$$

where the last expression is useful for determining the filter parameters.

The passband gain is the amplitude of the filter for frequencies that pass through without being affected. Since this is a high-pass filter, we can find the passband gain by setting $\omega \rightarrow \infty$:

$$H(j\omega) \Big|_{\omega \rightarrow \infty} = -\frac{R_2}{R_1}$$

Hence, $\frac{R_2}{R_1} = 8$

The cut-off frequency is where the amplitude is reduced to $\frac{1}{\sqrt{2}}$ compared with the passband gain. We

can observe directly that this is $\omega_c = \frac{1}{R_1 C}$, alternatively we can derive it:

$$|H(j\omega_c)| = \left| -\frac{R_2}{R_1} \frac{j\omega_c R_1 C}{1 + j\omega_c R_1 C} \right| = \frac{1}{\sqrt{2}} \frac{R_2}{R_1}$$

$$\sqrt{2} \omega_c R_1 C = \sqrt{1 + (\omega_c R_1 C)^2}$$

$$\omega_c R_1 C = 1 \Rightarrow \omega_c = \frac{1}{R_1 C}$$

Then we can find $R_1 = \frac{1}{4000 \cdot 2\pi \cdot 250 \cdot 10^{-9}} = 159.15 \Omega$

And $R_2 = 8R_1 = 1273.2 \Omega$

Comment: Students that got wrong answer in a) can still get full score on b) as long as they show the correct procedure.

In problem c) and d), assume $v_{in}(t) = 2.5 \cos(\omega t)$, where ω is unknown. Assume stationary conditions

c) Assume the op.amp operates in its linear region

Find the output voltage $v_{out}(t)$ when: I) $\omega = \omega_c$, II) $\omega = \frac{\omega_c}{8}$ III) $\omega = 8\omega_c$

Answer: We use the transfer function to find the amplitude and phase angle of v_{out} :

$$H(j\omega) = -8 \frac{j\omega}{4000 \cdot 2\pi + j\omega}$$

(the expression for H is slightly re-organized here to have a more clean expression)

$$|H(j\omega)| = \frac{8\omega}{\sqrt{(4000 \cdot 2\pi)^2 + \omega^2}}$$

$$\angle H(j\omega) = -90 - \arctan\left(\frac{\omega}{4000 \cdot 2\pi}\right)$$

We can then find the magnitudes and angles by inserting the frequencies

	$ H(j\omega) $	$\angle H(j\omega)$
$\omega = \omega_c / 8$	0.9923	-97.13
$\omega = \omega_c$	5.6569	-135.0
$\omega = 8\omega_c$	7.938	-172.9

Note that the input voltage has amplitude 2.5 and zero phase angle. We can then write the time-domain expression by the phasor transform:

$$\omega = \omega_c / 8 : v_{out}(t) = 2.4808 \cos(3141.6t - 1.6952)$$

$$\omega = \omega_c : v_{out}(t) = 14.14 \cos(25133t - 2.3562)$$

$$\omega = 8\omega_c : v_{out}(t) = 19.85 \cos(201060t - 3.0177)$$

Answer with alternative transfer function:

The alternative transfer function was specified in an unfortunate way. In addition, it was not entirely clear that the cutoff-frequency should be 4000 Hz. This will be taken into account during grading.

$H = \frac{V_{out}}{V_{in}} = \frac{6}{3500s + 1}$, finding the magnitudes and angles yields:

	$ H(j\omega) $	$\angle H(j\omega)$
$\omega = \omega_c / 8$	5.45E-7	-90
$\omega = \omega_c$	6.82E-8	-90
$\omega = 8\omega_c$	8.52E-9	-90

The time-domain functions are therefore relatively unrealistic (note the multiplication with 2.5):

$$\omega = \omega_c / 8 : v_{out}(t) = 1.36 \cdot 10^{-6} \cos\left(3141.6t - \frac{\pi}{2}\right)$$

$$\omega = \omega_c : v_{out}(t) = 1.71 \cdot 10^{-7} \cos\left(25133t - \frac{\pi}{2}\right)$$

$$\omega = 8\omega_c : v_{out}(t) = 2.13 \cdot 10^{-8} \cos\left(201060t - \frac{\pi}{2}\right)$$

Comment: This is very close to zero, and students that write $v_{out}=0$ will get part score.

- d) What is the smallest value of supply voltage V_{cc} that will cause the op amp to operate always in its linear region?

Answer: We can interpret the word “always” as “for all frequencies”. Then we must find the maximum amplification factor (gain) in the filter. This is the passband gain of 8. Consequently, when the input voltage has 2.5 V in amplitude, the output voltage will have a maximum amplitude of $8 \cdot 2.5 = 20 V$. If we then choose $V_{cc} = 20$ we have ensured that the op-amp will never saturate.

Similarly, with the alternative transfer function the minimum value will be $2.5 \cdot 6 = 15 V$.

4 DC-DC BUCK CONVERTER DESIGN FOR PHOTOVOLTAIC (PV) MAXIMUM POWER POINT TRACKING

<i>Irradiation level</i>	P_{MPP}	I_{PV}	V_{PV}	D	I_{batt}
1000 W/m ²	2.416	0.154	15.69	?	?
660 W/m ²	1.627	0.114	14.27	?	?
370 W/m ²	1.238	0.081	13.6	?	?

- a) Provide a schematic of the solution from the PV module to the battery load. Include a schematic of the DC-DC buck converter (step-down converter).

Answer: The following schematic shows the proposed system:

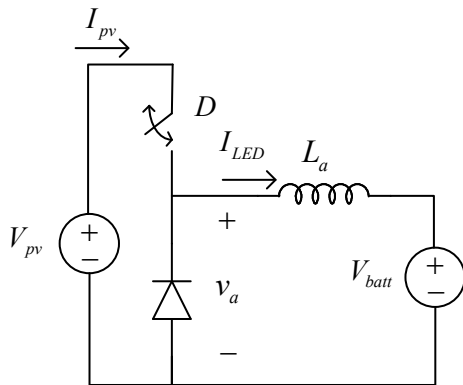

Comment: Other variants of this sketch can give some score, but students that only present the DC/DC-converter as a box will not get any points.

- b) If we operate the PV-module in Maximum Power Point condition at all irradiation levels, calculate the required duty cycle and average battery current. That is, fill in the cells with question mark in the table.

Answer: The duty-cycle in a buck (step-down) converter is the ratio between output and input voltage

$$D = \frac{V_{batt}}{V_{PV}}$$

In order to find the current in the battery, we use the fact that the PV-power is the same as the battery power:

$$I_{LED} = \frac{P_{MPP}}{V_{batt}}$$

<i>Irradiation level</i>	D	I_{batt}
1000W/m ²	$\frac{10}{15.69} = 0.637$	0.2416 A
660 W/m ²	$\frac{10}{14.27} = 0.70$	0.1627 A
370 W/m ²	$\frac{10}{13.6} = 0.7353$	0.1238 A

Comment: $I_{batt}=0.11$ A in the 370 W/m² case will also give full score (typo in the table)

c) Draw the inductor voltage and current for one switching period (only waveforms)

Answer: In the following sketch, two periods are included. In order to have full score, the voltage and current waveforms should have correct shapes. No values on the axes are needed, but the voltage should go negative during the off-period.

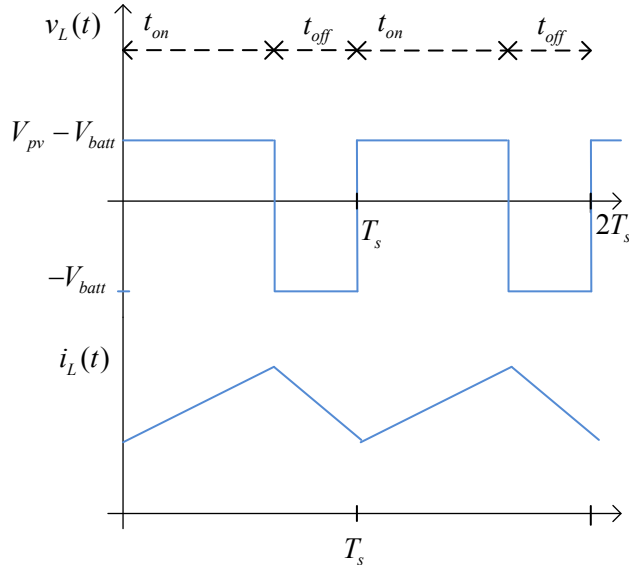

Assume now that the irradiation level is 1000 W/m^2 . We want to design the buck converter to have a peak-to-peak ripple current that is 10 % of I_{pv} . The switching frequency is 20 kHz .

d) Calculate the required inductance of the buck converter

Answer: We can find the peak-to-peak ripple ΔI_L by considering the inductor differential equation during the on-state period:

$$v_L = L \frac{di_L}{dt} \Rightarrow \int_0^{t_{on}} v_L dt = L \int di_L$$

$$(V_{PV} - V_{batt})DT_s = L \cdot \Delta I_L$$

$$L = \frac{(V_{PV} - V_{batt})DT_s}{\Delta I_L}$$

A ripple of 10% implies that $\Delta I_L = 0.1 \cdot 0.154 = 0.0154 \text{ A}$. We can then find the required inductance:

$$L = \frac{(15.69 - 10) \cdot 0.637 \cdot \frac{1}{20000}}{0.0154} = 11.8 \text{ mH}$$