

Norges teknisk-naturvitenskapelige universitet
Institutt for telematikk



**EKSAMENSOPPGAVE I TTM4115 – SYSTEMERING AV
DISTRIBUERTE SANNTIDSSYSTEMER
EXAM TTM4115 ENGINEERING DISTRIBUTED REAL-TIME
SYSTEMS**

Contact person/Faglig kontakt under eksamen:	Rolv Bræk
Phone/Tlf.:	415 44 605
Exam date/Eksamensdato:	01. juni 2012
Time/Eksamenstid:	09:00-13:00
Credits/Studiepoeng:	7,5 SP
Remedies/Tillatte hjelpemidler:	A: All written and handwritten examination support materials are permitted. All calculators are permitted A: Alle trykte og håndskrevne hjelpemidler tillatt. Alle kalkulatorer tillatt
Languages/Språkform:	
Antall sider bokmål:	1
Number of pages in English:	1
Tal på sider nynorsk:	0
Attachment/Antall sider vedlegg:	7
Results/Sensurdato¹:	22. juni 2012

¹ Merk! Studentene må primært gjøre seg kjent med sensur ved å oppsøke sensuoppslagene.

Bokmål (Eksamen utgjør 75% av slutt karakteren.)

Oppgavene referer seg til systemet som er beskrevet i vedlegg. Studer vedlegget først.

Oppgave 1. (30%) SDL

1. Definer *Carpool* systemet formelt som en SDL systemtype med *Parking Station Terminal* som en blokktype definert innenfor *Carpool* systemet. Ta med signaler på kanalene og signaldefinisjoner. (Ta bare med blokkene vist i Figur 1.)
2. Definer oppførselen til *Central Station* som en SDL prosessgraf (tilstandsdiagram) som tilfredsstill alle *cs* rollene referert i Figur 2 og detaljert i Figur 3 og 4. Ta med datadeklarasjoner og operasjoner (du kan bruke Java eller pseudokode til dette).
3. Definer oppførselen til *ctr* rollen i *ReturnKey* kollaborasjonen som en SDL sammensatt tilstand (composite state) som tilfredsstill sekvensdiagrammet i Figur 9. Ta med nødvendige datadeklarasjoner og operasjoner.
4. Anta at alle *ctr* rollene som spilles av *PSControl*, se Figur 5, er definert som sammensatte tilstander (composite states). Definer oppførselen til *PSControl* som en SDL prosessgraf (tilstandsdiagram) som benytter disse tilstandene.

Oppgave 2. (25%) Aktivitetsdiagram (Arctis form)

1. Konstruer en Arctis byggeblokk (building block) for *ctr* rollen i *ReturnKey* kollaborasjonen. Den skal tilfredsstill sekvensdiagrammet i Figur 9. (Samme rolle som i oppgave 1.3 over.) Anta at hver melding i sekvensdiagrammet representeres med en tilsvarende pin. Den indre aktivitetsflyten skal defineres.
2. Anta nå at hver av *ctr* rollene som spilles av *PSControl* er pre-definert som en Arctis byggeblokk med pins for hver av meldingene den mottar og sender. Konstruer en Arctis byggeblokk for *PSControl* som viser kontrollflyten mellom disse pre-definerte blokkene. Pinner (pins) som representerer meldinger til og fra de predefinerte blokkene skal vises men trenger ikke forbindes.
3. Forklar bruken av hendelse-mottak-aksjoner (receive event actions) til å fange opp hendelser fra brukergrensesnitt. Illustrer med et eksempel fra *Panel* der du antar at *Panel* er en GUI blokk.

Oppgave 3. (20%) Validering

1. Forklar hva som kreves for at en SDL prosessgraf (tilstandsdiagram) kan sies å tilfredsstill et sett med sekvensdiagram.
2. Forklar hva som menes med blandet initiativ (mixed initiative) og hvorfor det er viktig å kunne identifisere slike.
3. Forklar hva som menes med input konsistens og hvorfor det er viktig å sikre input konsistens.
4. Hva er formålet med ESM i Arctis?

English (The exam counts 75% towards the final grade.)

The questions refer to the system described in the appendix. Study the appendix first.

Question 1. (30%) SDL

1. Define the *Carpool* system formally as an SDL System type with the *Parking Station Terminal* as a Block type defined within the scope of the *Carpool* system. Include signals on the channels and signal definitions. (Consider only the blocks shown in Figure 1.)
2. Define the behaviour of the *Central Station* as an SDL process graph (state diagram) that satisfies all the *cs* roles referenced in Figure 2 and detailed in Figure 3 and 4. Include data declarations and operations (you may use Java or pseudo code for this).
3. Define the behaviour of the *ctr* role of the *ReturnKey* collaboration as an SDL composite state that satisfies the sequence diagram in Figure 9. Include the necessary data declarations and operations.
4. Assume that all the *ctr* roles played by the *PSControl*, see Figure 5, are defined as SDL composite states. Define the behaviour of the *PSControl* as an SDL process graph using these composite states.

Question 2. (25%) Activity diagrams (Arctis style)

1. Design an Arctis building block for the *ctr* role of the *ReturnKey* collaboration. It shall satisfy the sequence diagram in Figure 9. (Same role as in question 1.3 above.) Assume that each message in the sequence diagram maps to a corresponding pin. The internal activity flow shall be defined.
2. Assume that each *ctr* role played by the *PSControl* has been pre-defined as an Arctis building block, with pins corresponding to the messages it receives and sends. Design an Arctis building block for the *PSControl* showing the control flow among these pre-defined blocks. The message pins of the predefined blocks need not be connected, but shall be shown.
3. Explain the use of receive event actions to capture user interface events. Illustrate with a case from the *Panel* assuming that the *Panel* is a GUI block.

Question 3. (20%) Validation

1. Explain what is required for an SDL process graph to satisfy a set of sequence diagrams.
2. Explain the concept of a mixed initiative and why it is important to recognize mixed initiatives.
3. Explain the concept of input consistency and why it is important to ensure input consistency.
4. What is the purpose of an ESM in Arctis?

Vedlegg/ Appendix

English only

Carpool

We shall here study a system for carpooling as defined in Figure 1 (using UML). The system manages a fleet of cars that can be rented by registered *Users* for shorter or longer periods. The cars are available at *Parking Stations* where there are special *Parking Station Terminals* that have a *Key Safe*, a *Card Reader* and a touch display *Panel*. *Users* book cars by accessing the *Central Station* from mobile *User Clients*. The *Central Station* manages reservations using the interface collaborations specified in Figure 2 and detailed in Figures 3 and 4. The *Central Station* keeps track of *available* and *busy* cars by means of the *Check Out* and *Check In* collaborations defined in Figure 4. Datatypes used in the system are defined in Figure 10.

A car is picked up and returned at a *Parking Station* according to the procedure define by the *Car Pickup and Return* activity referenced in Figure 5 and defined in Figure 6. This is an activity diagram that defines an ordering of sequence diagrams. It is essentially an Interaction Overview diagram (which is the UML version of an HMSC diagram). The roles participating in each sequence diagram is indicated by partitions in the action symbols in order to help reading the diagram. The referenced sequence diagrams are defined in Figures 4,7,8 and 9.

At the parking station the user inserts a card in the *Parking Station Terminal*. The card carries a *CardID* that is used to identify the *User* and to fetch the *User's* current *Reservation* from the *Central Station*. If there is a current *Reservation* with status *reserved*, see Figure 10, the terminal will assume that the user is there to pick up a car. It will then identify the car and the corresponding *Slot* in the *KeySafe* where the car keys are stored and make the keys available for the user in a drawer as indicated in the *GiveKeys* collaboration in Figure 9. If the status of the current *Reservation* is *started* the terminal will assume the user is there to return a car. The user is then asked to fill in *TripData* information about mileage, fuel level and parking lot. When this is done the *KeySafe* will open a drawer to receive the returned car keys. If the returned *Reservation* is *void*, the user may pick up a car directly if one happens to be available (not detailed here).

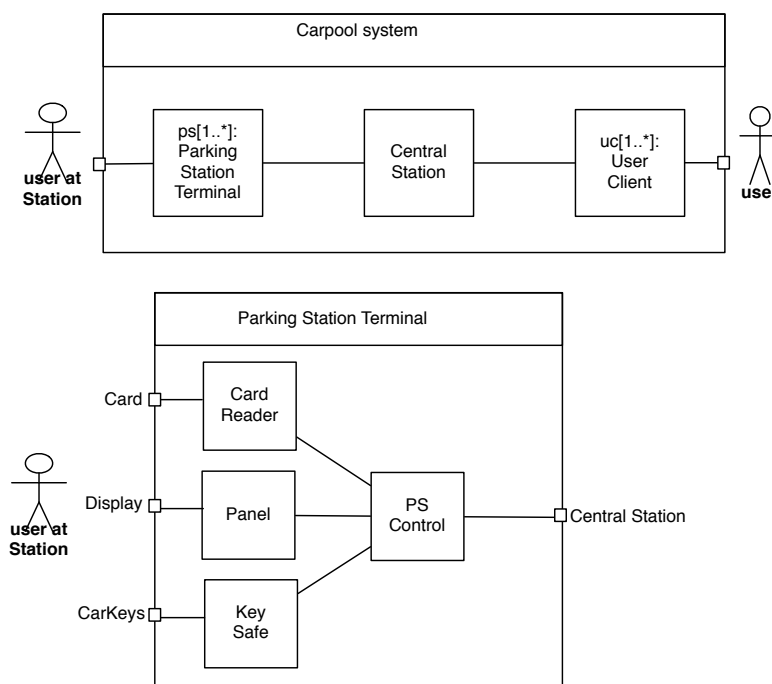

Figure 1 The Carpool system (UML notation)

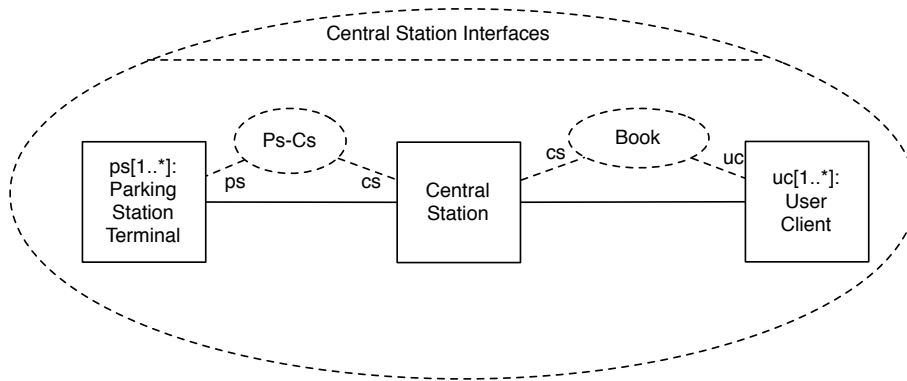

Figure 2 Central Station interfaces as collaborations

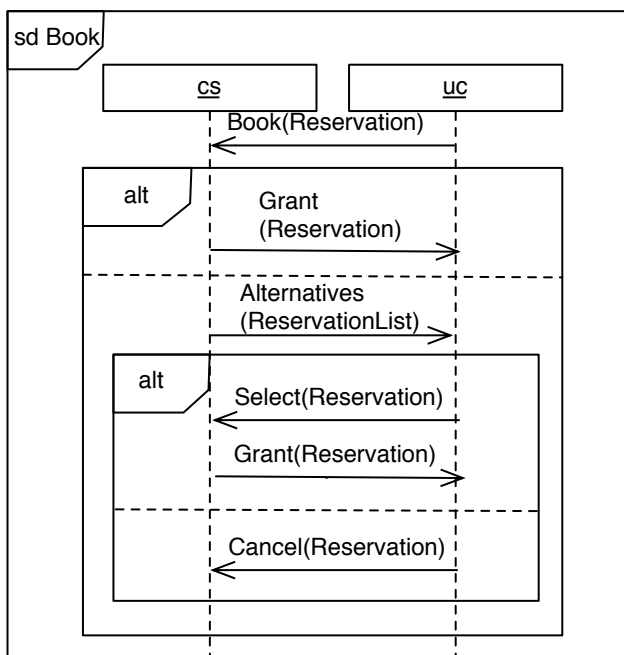
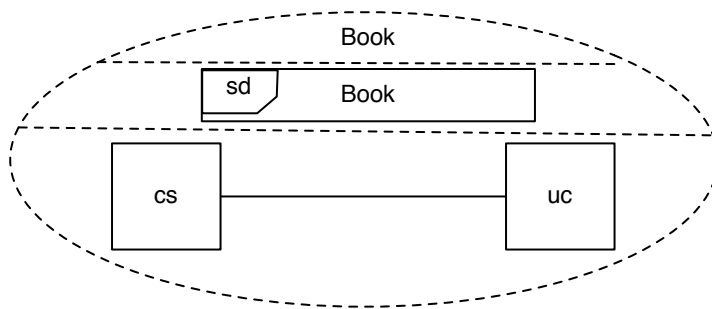

Figure 3 The Book collaboration

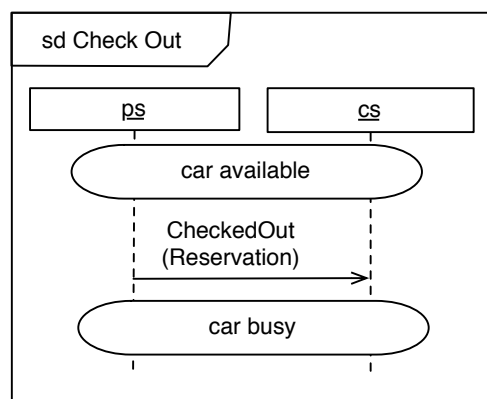
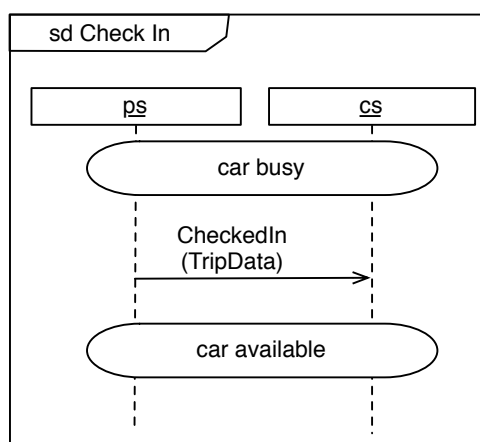
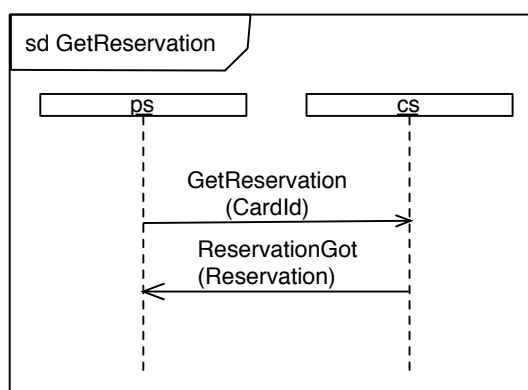
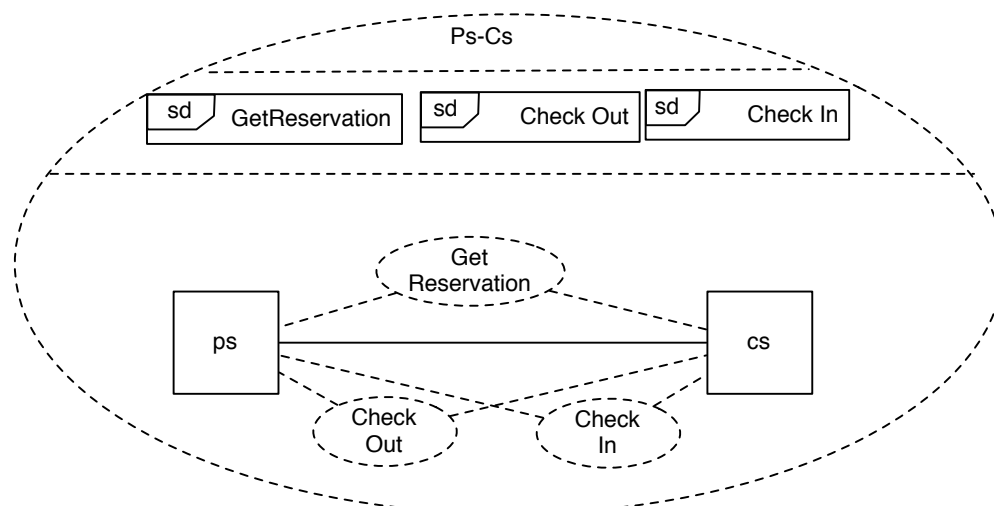

Figure 4 The Ps-Cs interface

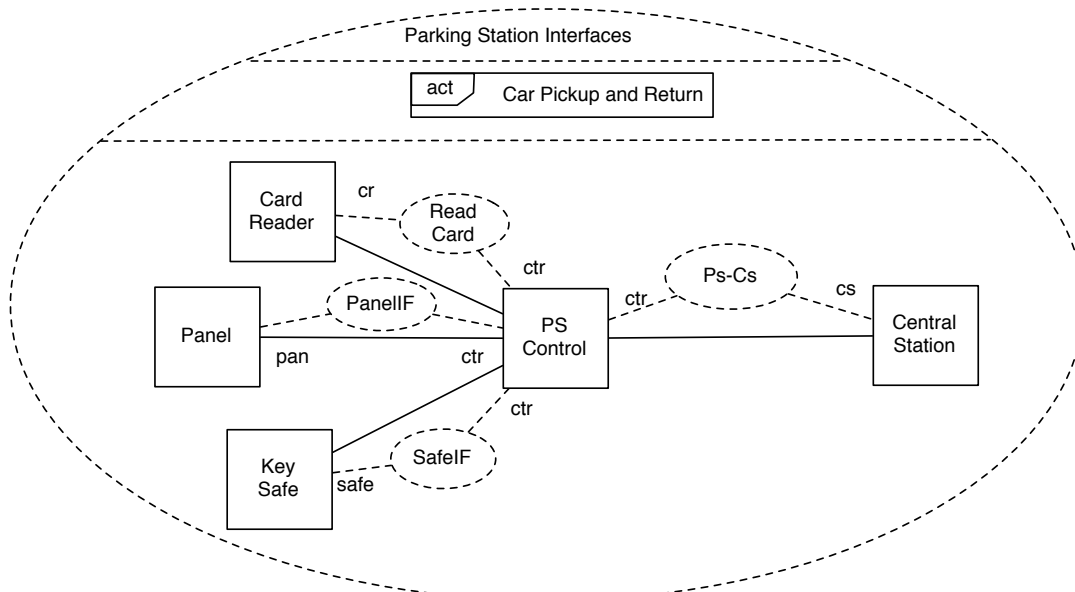
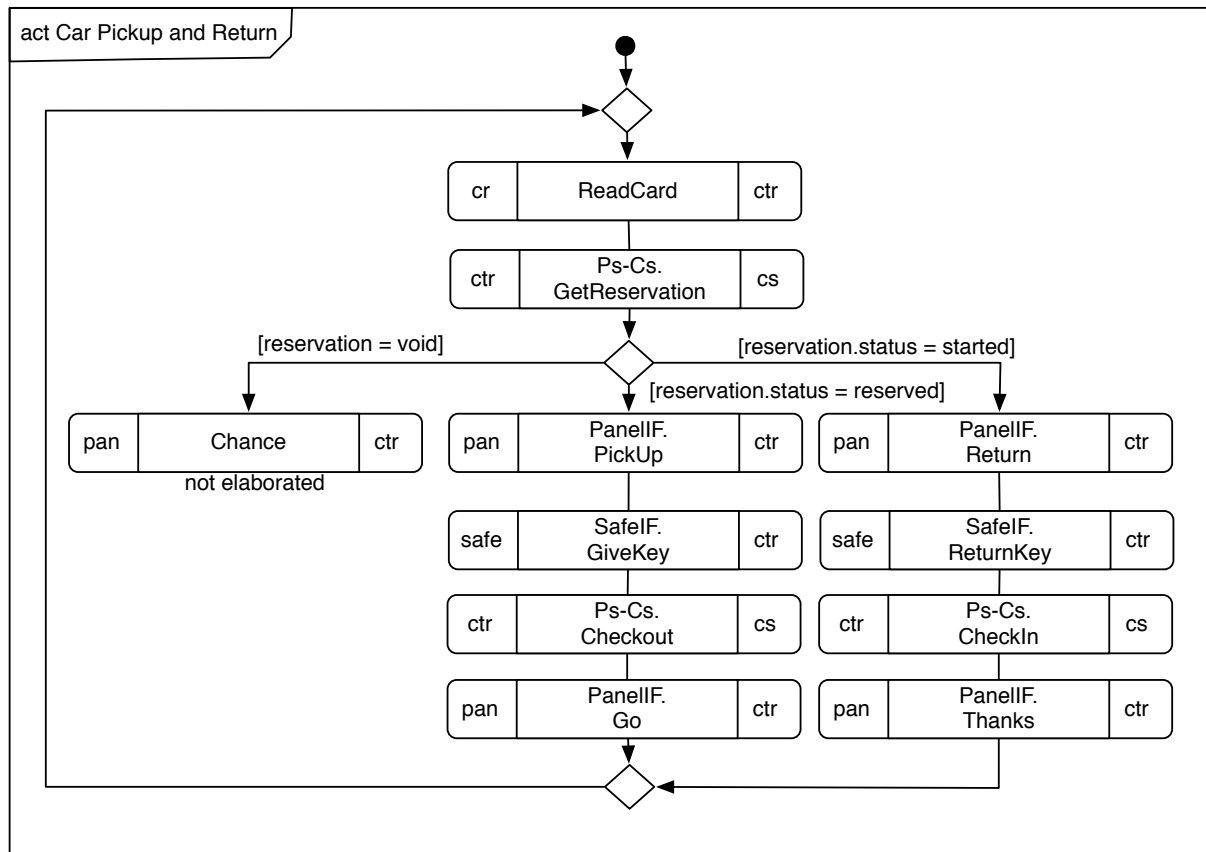

Figure 5 Parking Station Interfaces as collaborations



LEGEND:

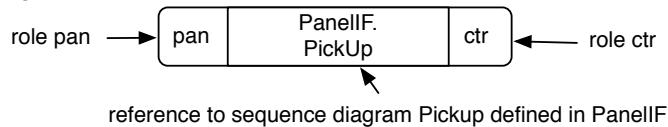

Figure 6 The Car Pickup and Return behaviour. The diagram is an Activity Diagram used like an Interaction Overview Diagram (UML) or HMSC (MSC). Actions refer to sequence diagrams having the roles indicated.

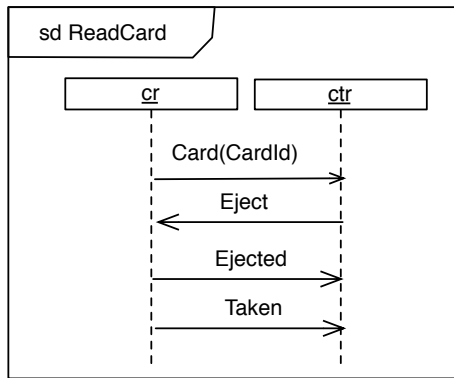
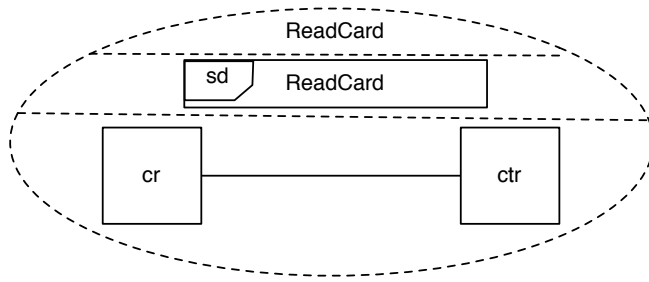

Figure 7 The ReadCard Collaboration

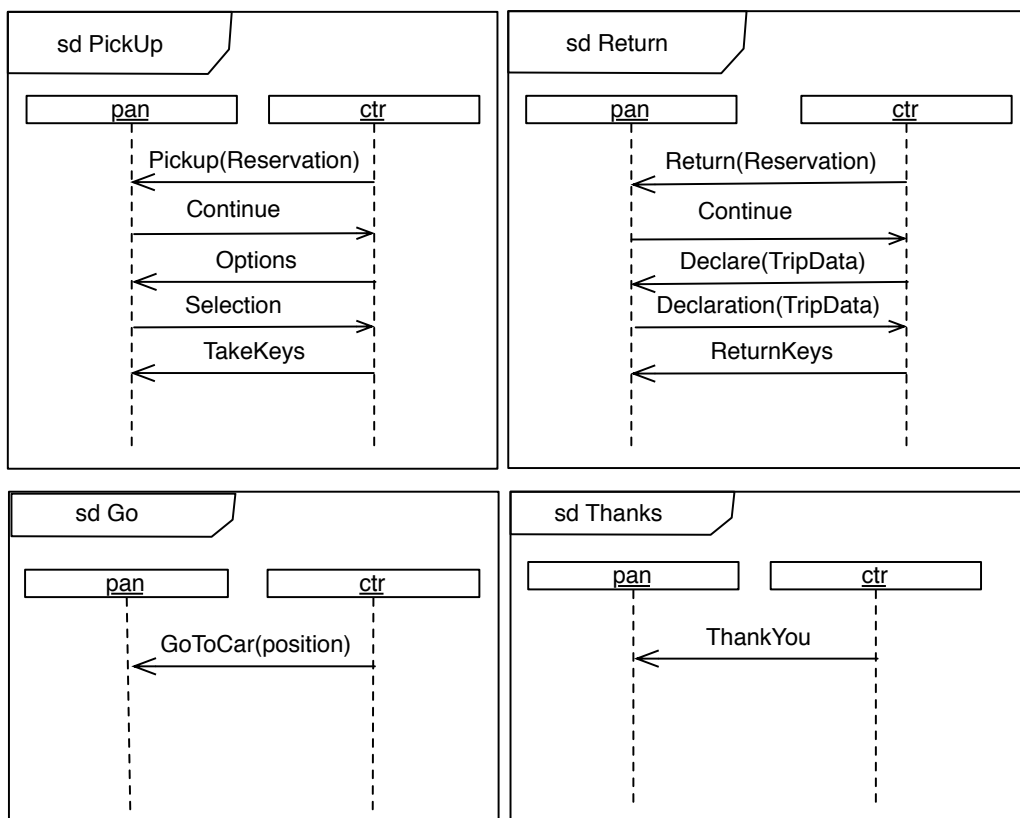
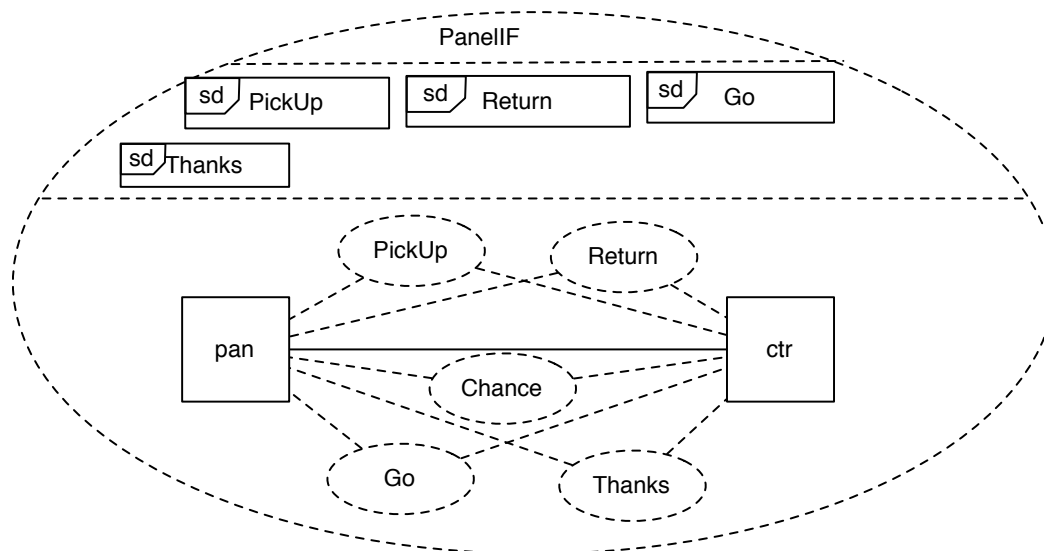

Figure 8 The PanellIF collaboration

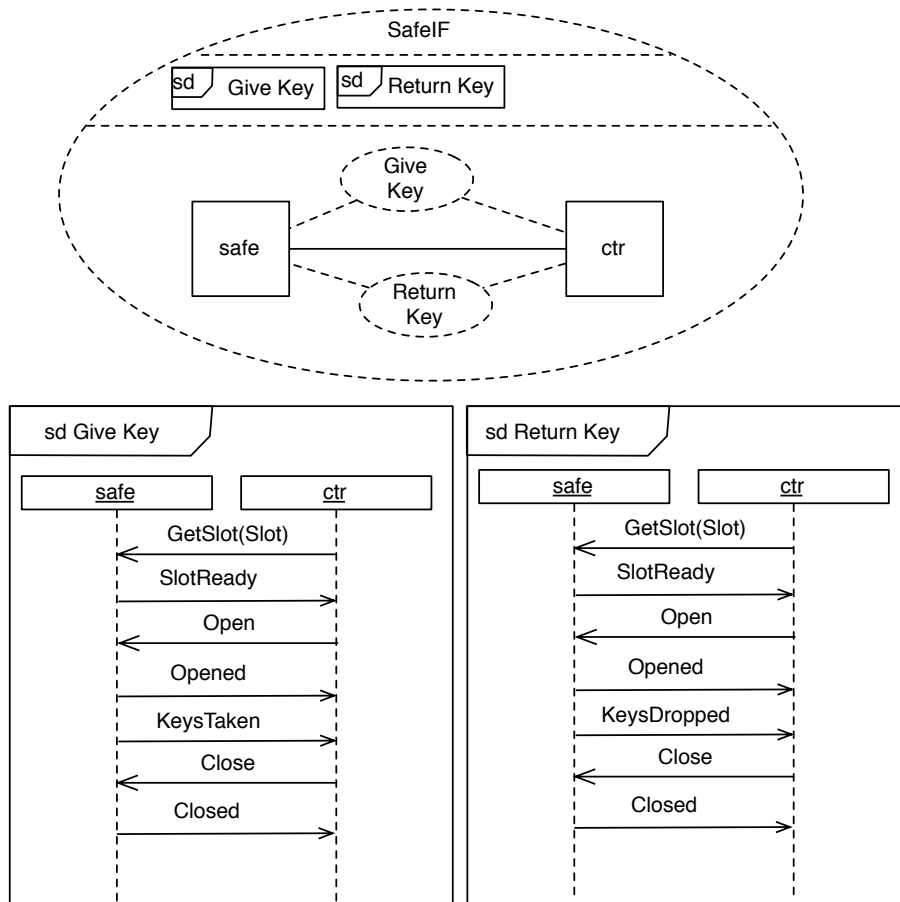

Figure 9 The SafelF collaboration

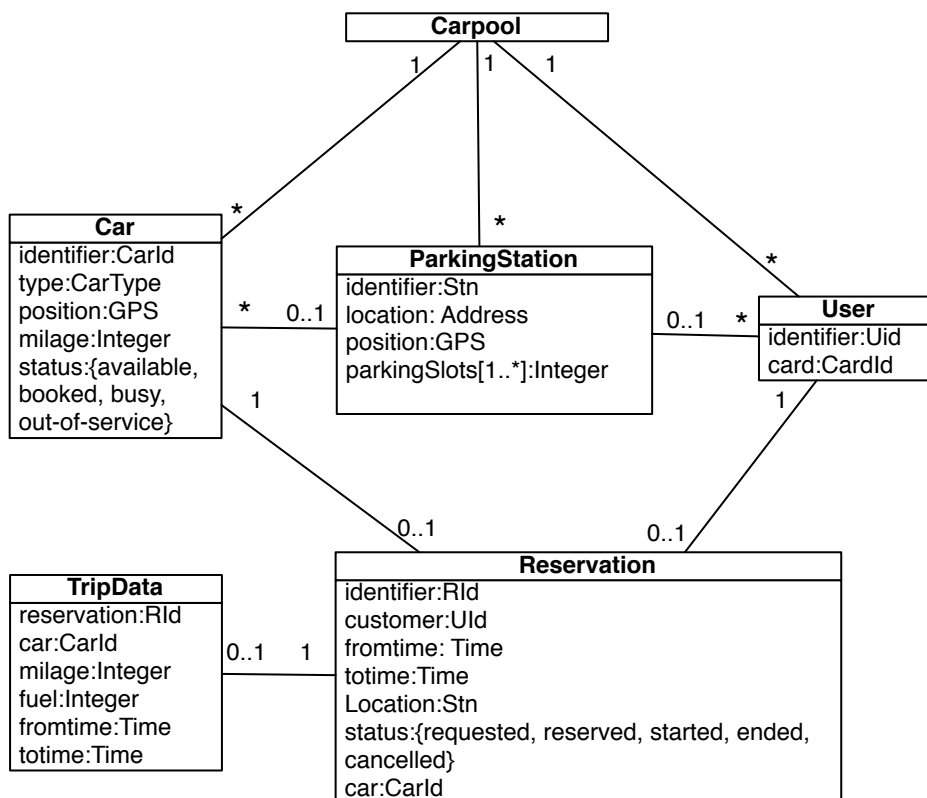

Figure 10 Data types in the Carpool system