

Field DGPS Report AT-329 2005



Ellen M. Sundlisæter
Lene Kristensen
Sigrid K. Dahl
Ulli Neumann

Table of contents

Table of contents.....	2
Introduction.....	2
Methods.....	3
Equipment.....	3
Availability.....	3
Setup.....	3
Data set 1.....	3
Data set 2.....	4
Processing.....	4
Data.....	5
Exercise 1 – Heights.....	5
Exercise 2 – Coordinates.....	6
Results – Baseline.....	9
Discussion.....	9
Conclusion.....	11
References.....	11

Introduction

One of the main themes on the course AT 329 Cold regions field investigation is getting knowledge about the global positioning system, GPS. From a geotechnical point of view, the information we gather with this system can be used on several different areas. On this course we've used them for finding data on mass balance of the Bogerbre, to find out how much water the glacier contributes to Isdammen (the water supply lake for Longyearbyen).

Because regular GPS receivers don't provide good enough accuracy, we've also learned about Differential GPS, an improved system which provides better accuracy. The purpose of Differential GPS (DGPS) is to reduce navigational errors made when using manual receivers, for example from Garmin or Magellan. This can be done by DGPS-stations that know their position very accurately, and has been static for a longer period (preferably for several hours). These stations broadcast the range errors they're seeing from each and every GPS satellite. Nearby DGPS receivers can use these correction messages, correlated with the satellite signals they're receiving, to give between 10 to 2 meter accuracy. The exact accuracy attained is a function of distance from the DGPS stations, and how rapidly the stations broadcast their data. If more than one station's data is used, and each is transmitting updates fast enough, we get accuracy down to millimetre level. Many DGPS stations intentionally transmit slowly to limit accuracy. The receivers constantly compare the real position with the position given by the GPS satellite system, and there are these stations we use as reference when we collect other positions on our surveys [1][2].

We used the Leica System 500 receivers, which can be operated on a tripod or pole, used in a minipack or vehicle, set up on a pillar or at a reference station [3]. We used them mainly on a tripod and on pole on our surveys.

Methods

Our main goal on our first survey, by the Sysselmann office on the 26th of February, was to get familiar with the system and the different modules. Here we used both the static and the stop and go-survey. The second survey took place at Bogerbreen on the 3rd of March.

On our first survey the 26th of February, we went up to Sysselmannen where we mounted up the tripod with our receivers next to the concrete pillar (the concrete pillar itself was already occupied by someone else's tripod). This specific point is regularly used as a reference point, and its coordinates are known (measured by the Norwegian Polar Institute). The main goal for the survey was mainly to get familiar with the system and try out both the static and the stop and go-survey. The system itself is very user friendly, but not very comfortable to operate on in minus 20 °C.

Equipment

Three GPS receivers from type Leica 500 has been used to gather the 2 data sets. All of the receivers have been equipped with Antennas from type AT201/AT302. During the surveys external batteries has been chosen in order to power the receivers with energy considering the subzero temperatures during the surveys.

Availability

To evaluate geometry of orbiting satellites and availability of transmitted satellite signals the software features of the Sky plot software were used. An estimated position of the two locations was surveys were carried out were obtained from a topographical map with a scale of 1:100.000.

Setup

By obtaining the two data sets different setups of equipment has been used and are described as follows [5].

Data set 1.

Survey took place at the 26th of February 2005 in close range of one of the major reference points on Svalbard next to the governors' office in Longyearbyen. Since the reference point itself on this day was engaged by another operation the receiver antenna has been placed beside it. A tripod came in use for this static survey. Control panel and external battery was placed in a hard case just underneath the tripod. The antenna height and offsets was included in the receivers' configuration. A 10 second elevation mask was set to 15 degrees. The receiver started logging and indicated by the status symbol in the display. To avoid multipath signals we kept some distance to the receiving antenna.

Further two receivers were assembled to operate in the static, stop and go mode. Receiving antennas were placed on a metal rod to be able to move from one survey point to another.

After entering the antenna height and type into the configuration, we started the initialization of the survey until the value on the display exceeded 120 percent. The antenna was then carried by the same person carrying the control panel and the external batteries. The antennas have been carried with as much care as possible to avoid losing the satellite signals. Several control stakes along the road were then surveyed.

After finishing the survey and storing of the data in the two “stop and go” operating receivers, the survey was also stopped and stored at the static operating receiver. Shortly after, the equipment was disassembled and brought to UNIS to download the data from the three memory cards.

Data set 2

On the 3rd of March 2005 another dataset was obtained in order to establish a local reference point at a glacier front from a nearby valley glacier called Bogerbreen. On the reference point at Sysselemane one receiver was set up in the early morning. The antenna was placed with some improvisation techniques directly above the bolt, and started logging in the static mode just before 09.00 AM this morning.

The local reference point was established on the eastern side of a side moraine of Bogerbreen. The antenna was placed on a tripod, and offsets and the antenna type and height were set in the system configuration. The elevation mask has been decreased to 10 degrees. Both channels L1 and L2 received signals from 10 satellites as indicated in the control panel display. Survey started at 11:45 with a sampling interval of 10 seconds.

The data collection of the planned rover survey was somehow not successful.

The receiver at the local reference point was taken down around 15:45 the same day. Shortly after the receiver at the reference point in Longyearbyen was taken down as well. The receivers were then returned to UNIS for post processing of the obtained data.

Processing

Ski pro software has been used to post process the recorded data and obtain positions of the “stop and go” survey and the position of the local reference point at Bogerbreen

Data

Exercise 1 – Heights

Point ID	Northing	Easting	Ell.H in m	Northing	Easting	Orthometric heights in m
WGS-84				ED-50		
NP 124 Syss	8683206.013	514280.690	66.8010	8683413.580	514344.531	34.0
Boger Ref	8674507.727	514177.525	485.7452	8674715.254	514241.393	454.0
Syssel Ref	8683192.590	514277.031	61.3799	8683400.157	514340.872	29.0
001	8683201.929	514293.267	60.6802	8683409.496	514357.107	28.0
003	8683231.595	514327.134	58.8390	8683439.163	514390.975	26.0
004	8683309.303	514305.440	54.0851	8683516.870	514369.281	22.0

Table 1. Transformed surveyed positions from data set 1 and 2

Use the Garmin receiver and measure a position at a point/place of your own choice.
Our coordinates:

Point: Sysselmannen, the concrete pillar
Latitude: 78° 13' 18''
Longitude: 15° 37' 18''
N (UTM): 8683206
E (UTM): 0514280
Height: 32 m

What is the value of the geoidal height in your point?
32 m, value of our GPS receiver

What is the ellipsoidal height?
32 m, value read from the EGM96 Geopotential model below; *long wave lenght* geoidal height model of Svalbard area computed from EGM96 global geopotential model in meters. Geodal heights are referred to GRS80 ellipsoid. The geoid is above the ellipsoid.

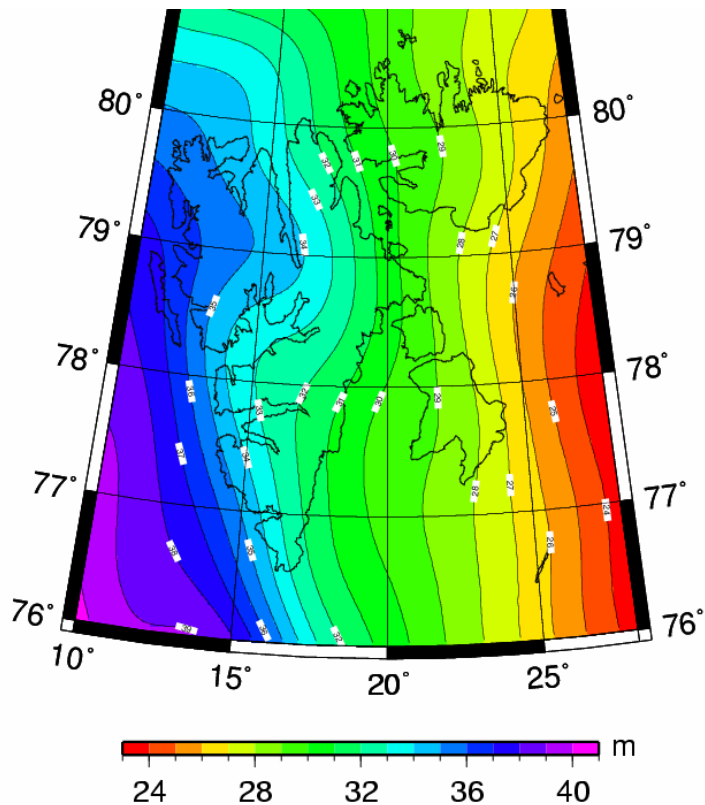

What is the height above sea level?
64 m (geoidal height + ellipsoidal height)

Exercise 2 – Coordinates

A point has the following coordinates and ellipsoidal height (WGS84):
Latitude: $\varphi = B = 78^\circ 09' 00.0''$ N
Longitude: $\lambda = L = 15^\circ 40' 00.0$ E Greenwich
Ellipsoidal height: $H_e = 220,00$ m

a) Calculate the X- and Y-coordinates in the geometric coordinate system (Cartesian coordinates).

For this exercise we used the program WSKTrans to transform the data to Cartesian coordinates.

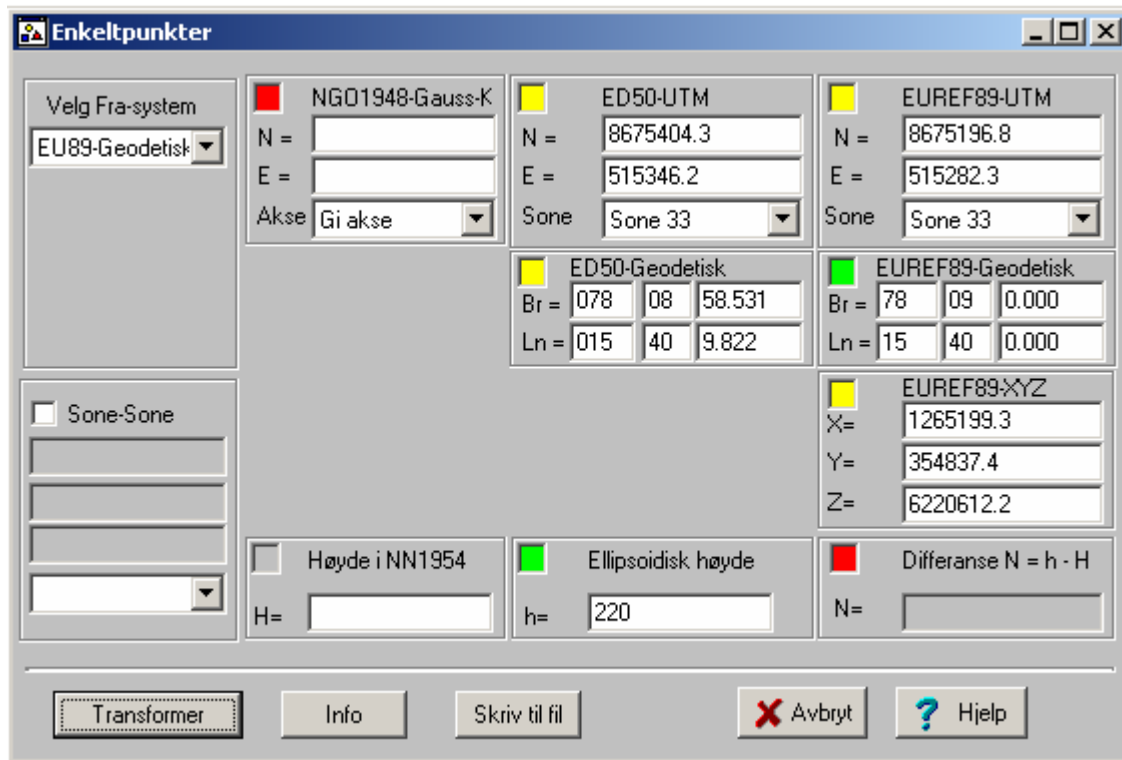

This gave us the Cartesian coordinates

X = 1265199.3 m

Y = 354837.4 m

Z = 6220612.2 m

We could also calculate the coordinates manually:

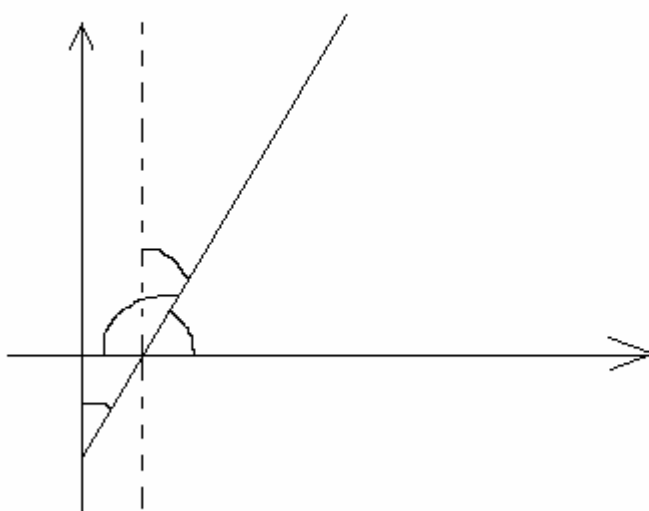

The values from the exercise:

$$\begin{aligned} \text{Latitude: } \varphi = 78^\circ 09' 00.0'' &\rightarrow 78 + 9/60 = 78,15 * \pi / 180 = 1,363283 \\ \text{Longitude: } \lambda = 15^\circ 40' 00.0'' &\rightarrow 15 + 40/60 = 15,67 * \pi / 180 = 0,273296 \\ \text{Ellipsoidal height: } H_e &= 220 \text{ m} \end{aligned}$$

This gives us, according to the drawing:

$$\theta = \pi - \varphi - \pi/2 = 0,206717$$

Calculate radians back to Cartesian coordinates:

$$R_N = 6398684,45 \text{ m}$$

$$\begin{aligned} X &= R_N * \sin(\theta) * \cos(\lambda) = 1\,264\,572,7 \text{ m} \\ Y &= R_N * \sin(\theta) * \sin(\lambda) = 354\,472,59 \text{ m} \end{aligned}$$

b) *The formula of the Z-coordinate is more complicated: $Z = [(b/a)^2 * R_N + H_e] * \sin \varphi$. Calculate the Z-coordinate in geocentric coordinate system. ($R_N = 6398684,45 \text{ m}$).*

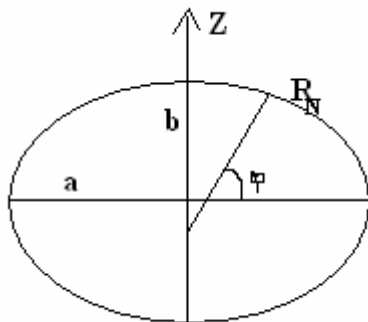

$$\begin{aligned} a &= 6378000 \text{ m} \\ b &= 6357000 \text{ m} \\ &\text{(given values)} \end{aligned}$$

$$Z = [(b/a)^2 * R_N + H_e] * \sin \varphi = 6220460,116 \text{ m}$$

c) *Why is not the ellipsoid normal on the figures crossing the centre of the ellipsoid?*

The ellipsoid is not circular, but slightly pressed down at the poles. That's why the normal vector never will cross the centre, but either pass by it or not quite reach it.

d) *Why do we in Norway use an average radius of the earth of 6390 km, when the semi axis of the ellipsoid is approximately 6378 and 6357 km?*

In Norway we use the radius of the curvature to measure the radius. Seeing as the earth (or the ellipsoid) is not circular, we see that the radius of the curvature where Norway lies is

bigger than both the radiuses of the curvature at the equator and at the poles. That's why the radius in Norway is bigger than most other places in the world.

Results – Baseline

Project Information

Project name:	Boger DGPS
Date created:	03/10/2005 17:50:40
Time zone:	1h 00'
Coordinate system name:	Oppdal S
Application software:	Leica SKI-Pro 3.0
Processing kernel:	PSI-Pro 1.0
Processed:	03/10/2005 18:05:54

Final Coordinates

	Reference: syss	Rover: ref 2	
Coordinates:			
Latitude:	78° 13' 18.69853" N	78° 08' 38.16558" N	
Longitude:	15° 37' 36.17916" E	15° 37' 05.36990" E	
Ellip. Hgt:	66.8010 m	485.7452 m	
Solution type:	Phase		
Frequency:	L1 and L2		
Ambiguity:	Yes		
Quality:	Sd. Lat: 0.0011 m Posn. Qlty: 0.0015 m	Sd. Lon: 0.0011 m Sd. Slope: 0.0009 m	Sd. Hgt: 0.0042 m
M0:	1.4278 m		
Cofactor matrix Qxx:	0.00000057	0.00000001 0.00000054	0.00000166 -0.00000011 0.00000884
Baseline vector:	dLat: -0° 04' 40.53295" Slope: 8712.8106 m	dLon: -0° 00' 30.80926"	dHgt: 418.9442 m
DOPs (min-max):	GDOP: 2.3 - 15.5 PDOP: 2.0 - 13.1	HDOP: 0.8 - 5.0	VDOP: 1.9 - 12.5

Table 2. Results from Baseline computation SysseImann to Bogerbreen

Discussion

An important factor by conducting GPS survey methods is the availability of satellite signals and their geometry. For both data sets the features of the Skyplot software was used to forecast the availability and geometry for the known points of the survey as shown below. Despite the high latitude of Svalbard, a reasonable amount of received signals were obtained mostly 10-11 on both signals L1 and L2. Due to horizon obstacles for the receiver on

Bogerbreen availability has been reduced resulting in a slightly higher PDOP value in comparison to all other receivers.

For all surveyed positions, the ambiguity has been solved within the post processing procedure. Nevertheless there are several errors sources to consider. Errors are derived by increasing length of the baselines. Comparing data set 1 and 2, positions obtained from data set 1 are more accurate due to baselines less then 200 m. The local reference point on the Bogerbreen moraine is surveyed with a Baseline of approximately 8 km and therefore less accurate. Multipath errors were more likely to occur on dataset 1 due to the presence of cars and houses next to the receiver antenna. In the data set 2 it's less likely that Multipaht errors occur. Cycle slips occurring during the cinematic stage of data set 1 increase errors in the surveyed positions. The change of atmospheric conditions adds to the total error budget if you compare the two data sets, but within the dataset it is neglectable. This is due to the relative surveying technique and the small spatial extension where the atmospheric conditions were assumed to be equal. Beside those errors, satellite orbit error, satellite clock error and measurement noise add as well to the total error budget [4].

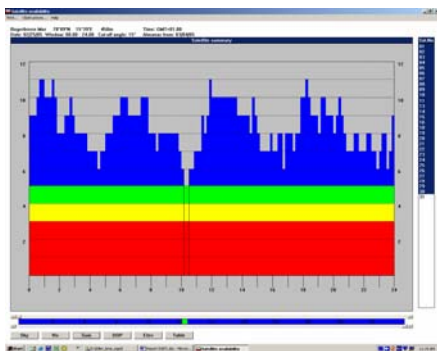

Figure 1. Skyplot for GPS availability for Bogerbreen 02.03.2005

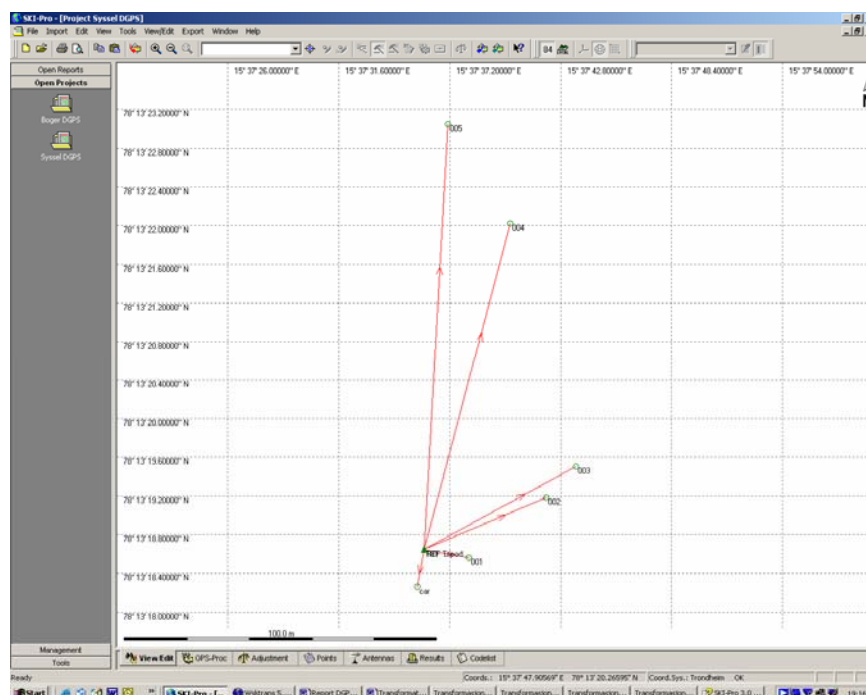

Figure 2. Visual view of baseline computation in Skipro software

Conclusion

The used DGPS method is a suitable to measure positions on the ground surface in a cost and time efficient manner. The static mode is more time consuming but gives more accurate positions. The stop and go cinematic method is very time efficient but is less accurate than static survey. Post processing in the way we used it reduces equipment such as radio transmission and make the method also less vulnerable to the harsh arctic climate. In comparison from Code receivers to the here used phase receivers, the difference of accuracy lies within meters of range. In many fields of work the accuracy decides which system to use.

References

- [1] <http://www.eurofix.tudelft.nl/dgps.htm>
- [2] http://www.oreillynet.com/pub/a/wireless/2000/12/29/two_gps.html
- [3] <http://www.leicaatl.com/support/gps/Sys500Summary.pdf>
- [4] Hossein, N. V., Global positioning System, Course notes in AT-329, (2005)
- [5] Course notes in AT-329, (2005), manual: Leica GPS receiver, System 500